

IF IN DOUBT ASK
DO NOT SCALE

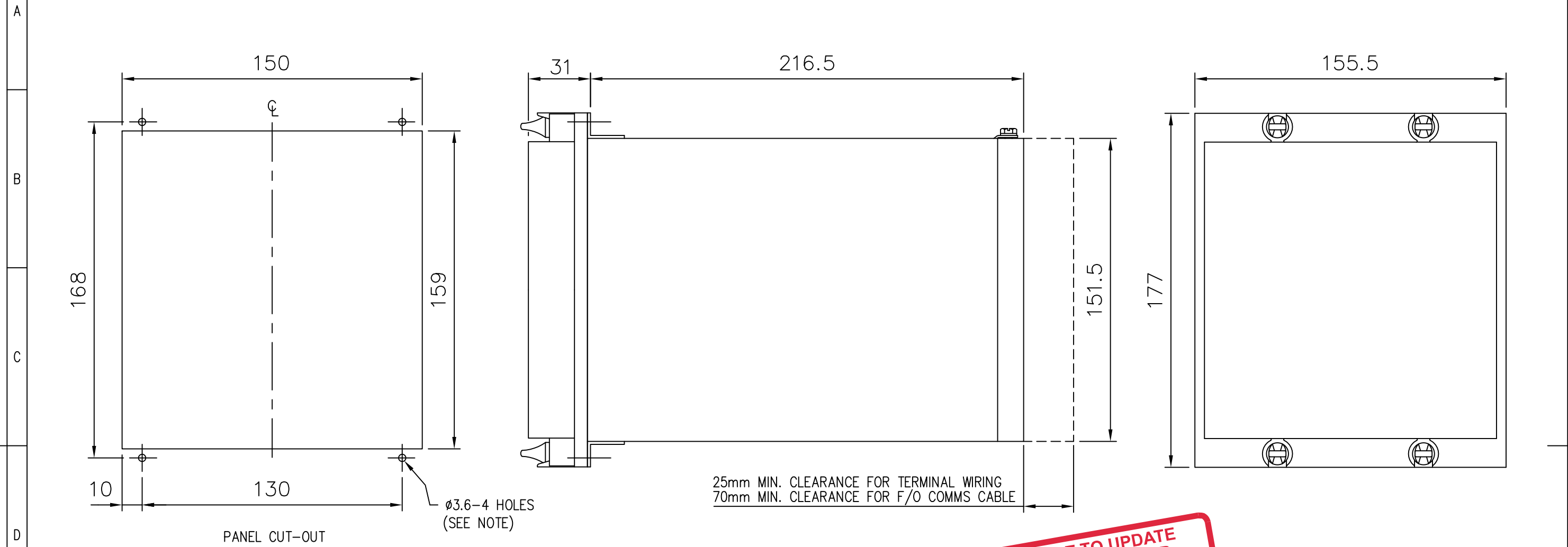

**NOT SUBJECT TO UPDATE
ONCE COPIED / PRINTED
OR DOWNLOADED**

NOTE:
THE $\phi 3.6$ HOLES ARE FOR M4 THREAD FORMING (TRILOBULAR) SCREWS. THESE ARE SUPPLIED AS STANDARD AND ARE SUITABLE FOR USE IN FERROUS/ALUMINIUM PANELS 1.6mm THICK AND ABOVE. FOR OTHER PANELS, HOLES TO BE M4 CLEARANCE (TYPICALLY $\phi 4.5$) AND RELAYS MOUNTED USING M4 MACHINE SCREWS, NUTS AND LOCKWASHERS (SUPPLIED IN PANEL FIXING KIT).

DRAWING OFFICE ONLY NOTE
ANY CHANGE TO THIS DRG MUST BE REFLECTED
ON DRG 2995X10017 & CATALOGUE

4 RDW	04/06/07	MN995/2883 (AL)
3 RDW	27/09/06	MN995/2462(ML/RDW)
2	30/7/01	MN995/2125
1	12/07/00	CHANGE
ISSUE	DATE	NOTED \triangle

MATERIAL:

Dimensions in millimetres ; Surface texture in micrometres. Machine where marked \checkmark For explanation of dimensions, tolerances, notes etc. see B.S.308. Limit on untoleranced unmachined dimensions \pm _____ Limits on untoleranced machined dimensions to B.S.4500; i.e. up to 6 ± 0.1 ; over 30 to 120 ± 0.3 ; over 315 ± 0.8 ; over 6 to 30 ± 0.2 ; over 120 to 315 ± 0.5 ; General unmachined angular tolerance \pm _____	Finish:	Title: OVERALL DIMENSIONS AND PANEL DRILLING FOR EPSILON E6 CASE.	First used on:
	Treatment:		Original Scale.
		SIEMENS PROTECTION DEVICES LTD.	Drg. No. 2995X10006
DRAWN A.LAW	CHECKED	APPROVED	